

Leadership Message

I have been involved with Toronto SPIN (Software Process Improvement Network) since 2001 when the original founders were still leading and shaping the future of this organization. Years have passed, people have moved on, and new people have joined, yet I find myself still excited to be part of this team. The opportunity to meet like-minded people who care about process improvement and to learn from the very qualified and dedicated people that volunteer their time in the form of committee volunteers and speakers keeps me here.



We have been through at least two major internal transformations since I have been on the Steering Committee.

The first one was around 2002/2003 when we moved from a purely sponsorship-based funding model to an event-fee based model. This change was well received by our members and by 2005, we had been able to hold more events in one year than ever before in our history.

Our most recent transformation took birth at the beginning of 2007 when the Steering Committee met to determine what we wanted the future of this organization to be – and how that vision could be realized. To make sure we were building a strategy that was based on direct input from our members, in fall of 2007, we ran the first ever “Perception & Needs Survey” to understand what software process professionals in the Greater Toronto area were interested in and what they expected of Toronto SPIN. The results are being used as input to our transformation.

One component of our strategy is to significantly increase our volunteer base. Historically, we have had about 5-7 active volunteers, on average. At this time, we have over 20 active volunteers. This enables us to ramp up the activity level and provide more value back to the community. It is also a more satisfying experience for volunteers to be part of an organization where there is ‘action’ and the opportunity for gaining leadership experience.

I believe we are truly poised for significant growth in the coming years – continued growth of our volunteer base, introduction of new membership benefits, new programs and new opportunities to engage with each other. A community organization like Toronto SPIN is only as good as the level of involvement and interaction that it has with the community – I hope you will come and join us in this journey.

*By Rekha Kulshreshtha
TSPIN President*

What's Inside

This month's issue of the Toronto SPINner includes...

- **Introducing the Toronto SPINner..... page 1**
- **About Toronto SPIN page 2**
- **Perception and Needs Survey..... page 2**
- **Recent Activities..... page 3**
- **Upcoming Activities page 4**
- **Call for Sponsors..... page 4**
- **Special Feature page 5**
- **News from SEI..... page 6**
- **Call for Volunteers..... page 7**
- **Toronto SPIN Volunteer Team..... page 7**

Please submit any feedback on this newsletter as well as articles and digital photographs for consideration in future issues to communications@torontospin.com.

Introducing the Toronto SPINner

I am pleased to introduce the first issue of the Toronto SPINner. I hope you will find the content informative, interesting and valuable.

There are two reasons that we are introducing this newsletter now.

Firstly, over the last year, the level of Toronto SPIN activity has grown significantly. With this growth, we are experiencing an increase in the frequency and volume of information that we want to communicate to you. We do not want to send many individual email messages so consolidating useful information in one email per month in a newsletter format makes sense.

Secondly, we received feedback in our survey that people would like more ways to engage with the software process community in the Greater Toronto Area. We would like to encourage people to submit thought-leadership Special Feature articles and knowledge-sharing content for inclusion in future issues. You will find one such Special Feature in this issue.

This is our first monthly issue – we will continually evolve and improve it based on our own lessons learned and your feedback. Please participate – send your comments, feedback and articles for consideration to communications@torontospin.com.

*By Victoria Johnston
TSPIN Communications Sub-Committee Lead*

About Toronto SPIN

Since this is our first issue, we thought we would share a bit of general information about Toronto SPIN.

The Toronto SPIN vision is to promote world-class software development in the Greater Toronto area. Our objective is to promote process improvement, higher process maturity, and high quality software-based products through an active program, along and in conjunction with like-minded organizations.

The Toronto SPIN, formed in 1997, exists to create a series of discussion forums to exchange software engineering ideas, expertise, and experiences in the Toronto community. It intends to promote improvement of practices, increase process maturity levels, and raise the quality of software products developed in the Toronto area through an active program in partnership with other groups and associations.

A Software Process Improvement Network (SPIN) is composed of individuals who want to improve and share ideas and experiences on software engineering practices.



SPINs have been formed around the world and are allied to the Software Engineering Institute (SEI) where software process assessment and the Capability Maturity Model Integration (CMMI®) were developed.

Our goal is to help sustain commitment and enhance skills in the area of software process improvement through an active program of networking, presentations and professional support.

Steven Turner
TSPIN Secretary

...your gateway
to the people and
organizations
concerned with
the improvement
of software
quality

www.TorontoSPIN.com

Perception and Needs Survey

Based on some feedback from members of the community, a number of the Steering Committee members began to wonder about the level of interest in the Toronto area, related to CMMI and software process improvement and the relevance of the TSPIN mission.

To obtain objective data on this, the Steering Committee launched a "Perception and Needs Survey" in fall of 2007 to understand:

- The level of interest in, and the importance of, CMMI
- The level of interest in formal process improvement
- Whether the Toronto SPIN programs / speakers were delivering value

The survey had both an online and interview component with questions organized in 3 major categories:

- What is the interest in formal process improvement in general, and CMMI in particular?
- What are the community's interests and needs in the area of software process improvement?
- What is the perception of Toronto SPIN?

The results of the Perception and Needs Survey that was run by Toronto SPIN in the 4th Quarter of 2007 are available for download on our website at <http://www.torontospin.com/torontospin/membership.shtml>. These results have been approved by the Toronto SPIN Steering Committee and are presented in two parts - a short summary and a full report with more detailed results.

Toronto SPIN received much interesting and valuable feedback, which is now being taken into consideration as plans for future programs are developed.

Many thanks to all of those who made this survey successful: the Toronto SPIN Survey Team and those who took the time to respond to the survey and answer questions during interviews. Congratulations to our two survey prize winners: Andrew Gurudata, Telus and Gordana Maric, BMO.

David Penty & Winifred Menezes
TSPIN Survey Managers

Call for Event Venues

We continue to need meeting rooms to hold our conference events. The more we can find free access to meeting rooms in the Greater Toronto Area (especially downtown), the more able we are to hold events in different parts of the city.

If you have a meeting room that holds approximately 50 people and would be willing to make the room available for Toronto SPIN events, please contact us at programs@torontospin.com.

Ruben Montero

® SSMCMM Integration and SCAMPI are service marks of Carnegie Mellon University.

® CMMI, Capability Maturity Model, Capability Maturity Modeling, and CMM are registered in the U.S. Patent and Trademark Office by Carnegie Mellon University.

Program Sub-Committee Lead

Recent Activities

In this section, we will provide a glimpse of some key recent Toronto SPIN events and activities. Remember that final speaker presentations are available on our website for your reference at <http://www.torontospin.com/torontospin/events.shtml>.

February 2008 Event

The February Event theme was “Agility at Scale: Applying Agile Software Development Techniques on Real-World Projects”.

We welcomed back the dynamic presentation team of Scott Ambler and Kevin Aguanno. Scott and Kevin had presented together at Toronto SPIN in April 2005 to a packed room full of passionate attendees.



Scott Ambler at TSPIN

The popularity of this team is evidenced by the fact that we received requests from people on the other side of the world and from south of the border asking if there was any way they could participate in this event through the web. While we don't have that capability today, our web team is certainly investigating possibilities for the future.

As strongly held viewpoints were expressed, passion was not lacking in our February event, as is predictable with this particular presentation team and 36 experienced professionals from our community.

The event was held in the IBM auditorium at 3600 Steeles Avenue East in Markham. Many thanks to IBM Canada for offering the venue for this event.

Andrew Gurudata

TSPIN February 2008 Event Manager

Toronto SPIN Has Moved!

This is to notify all Toronto SPIN members that our physical ‘snail-mail’ mailbox has moved.

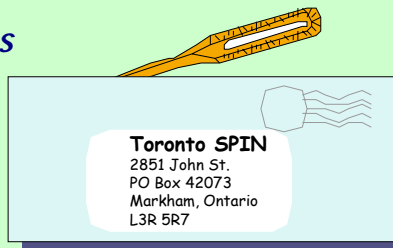

To ensure timely pick-up of mail, we have recently moved to a location more convenient for our volunteer team. Please make note of our new mailing address.

Doris Concepcion

TSPIN Finance Sub-Committee

March 2008 Event

Toronto SPIN often collaborates with other like-minded organizations in the Toronto area to offer additional value to our members.

In March 2008, we worked with the Toronto COBIT User Group to bring a special event to the Toronto Community – The “Big 3”: COBIT, ITIL, & CMMI.

On behalf of Toronto SPIN, Michael Raftus, of GrafP Technologies Inc. presented the CMMI component of this session. The event was held at the Toronto Board of Trade at First Canadian Place in downtown Toronto.

Many thanks to Robert Fabian for coordinating the collaboration across itSMF Canada, Toronto SPIN and CIPS Toronto to bring this event to the Toronto community.

Winifred Menezes

TSPIN Point of Contact

April 2008 Event

Based on feedback from past event attendees, there continues to be a very high degree of interest in the measurements topic area. So our event theme for April was Measurements, and based on a quote from Neils Bohr: "Prediction is very difficult, especially about the future".



David Card at TSPIN

We were delighted to have a speaker, David Card, the Managing Director of DNV ITGS, Inc. come all the way from Houston to present on “Integrating Lean, Six Sigma, and the CMMI: A Measurement Perspective”.

Our second speaker, Alfred

Allik, the head of Quality Assurance at BMO Financial Group, added a very Canadian perspective based on his lessons learned in his presentation “Measurements for CMMI ML4: Critical Success Factors”.



Alfred Allik at TSPIN

This event was also held in the IBM auditorium at 3600 Steeles Avenue East in Markham to an audience of 39 people. Many thanks to IBM Canada for making the venue available for this event.

Orhan Kalayci

TSPIN April 2008 Event Manager

Upcoming Activities

In this section, we will highlight a bit about upcoming events. Stay tuned, as more information about these

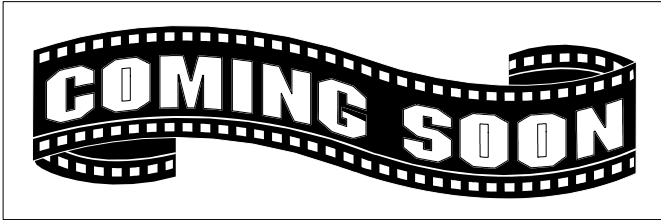

events and activities becomes available. Please register, if you plan on attending an event, as we use registration information as a basis for refreshment orders.

June 2008 Event

This month's event is on "Use Cases and Estimation". The first presentation, by Li Fang of IBM Canada, will provide the audience with an introduction to Use Cases. This will be followed by a presentation on the application of Use Case Points for software estimation in the context of maintenance by Sergey Diev, from Bank of Montreal.

Rekha Kulshreshtha
TSPIN June 2008 Event Manager

September 2008 Event

A call for speakers was issued to all Toronto SPIN members on May 9th, 2008 soliciting abstracts and biographies on the topic of 'Estimating'. We'd like to thank all potential speakers who submitted their abstracts and biographies.

The Program Sub-Committee has reviewed and selected two speakers and is working on finalizing event logistics. A poster will be published very soon.

Ruben Montero
TSPIN Program Sub-Committee Lead

Networking Event

We have always struggled to strike the balance between knowledge-sharing through formal presentations and providing networking time at our conference events. Our members have given feedback that both are valuable, but there never seems to be enough time for networking.



So this year, we've decided to hold our first ever networking event – which we hope will become an annual activity. Our goal is to bring together past and present sponsors, speakers, members and volunteers for a fun-filled evening in the fall.

We have already started collecting door prizes for this event – if you'd like to contribute a door prize, please send a note to communications@torontospin.com.

Stay tuned over the coming summer months for more details on this event.

Jenna Munro
TSPIN Networking Event Manager

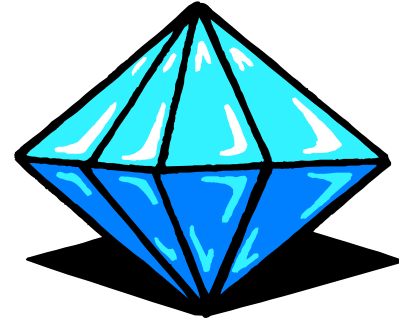

Will you be our Diamond Sponsor?

Call for Sponsors

Toronto SPIN is launching a new and improved Sponsorship Program for the August 2008 - July 2009 period.

There are 5 levels of sponsors. All levels cover a 12 month sponsorship period. With the exception of the Diamond level, there can be multiple sponsors per level.

- Diamond - exclusively awarded to one individual or organization that is the highest bidder - with bidding to start at \$3,500.00 Cdn (Please note that we currently have a sponsor who has submitted the starting bid)
- Platinum - \$3,000.00 Cdn
- Gold - \$2,000.00 Cdn
- Silver - \$1,000.00 Cdn
- Bronze - \$500.00 Cdn

For more information about the TSPIN Sponsorship program, please go to the Sponsors page on our website at

<http://www.torontospin.com/torontospin/sponsors.shtml>.

If you are interested in bidding for the Diamond Sponsor category, please submit your bids to sponsorship@torontospin.com. The bidding process will be open until July 7th, 2008. All individuals or organizations that submit a bid will be notified of the most current highest bid received and total number of bidders **until 5:00 pm EST July 7th, 2008**. The final winner will be notified by email. All bidders will be informed of whether they were outbid or not 2 business days after the bidding closes.

Please send a note to sponsorship@torontospin.com if you are interested in becoming a sponsor.

Renay Langdon
TSPIN Sponsorship Sub-Committee

Special Feature – What’s new from the Software Engineering Institute (SEI)

The SEI has initiated several initiatives since v1.0 of the CMMI® was released in Aug 2008. In this Special Feature Article, I will briefly touch on the varied initiatives and the status of each of these.

Capability Maturity Model Integration (CMMI)

The CMMI aimed to integrate the CMM for Software (SW-CMM), the CMM for Systems engineering (SE-CMM) and the CMM for Integrated Product Development (CMM-IPD). These models had different structures, so v1.0 as well as v1.1 of the CMMI was released as two documents – the staged representation (similar to SW-CMM) and the continuous representation (similar to SE-CMM). The content in both representations is 99% the same – the representations were just different views of the same material. The earlier years of the CMMI was coloured by some confusion around disciplines and representations.

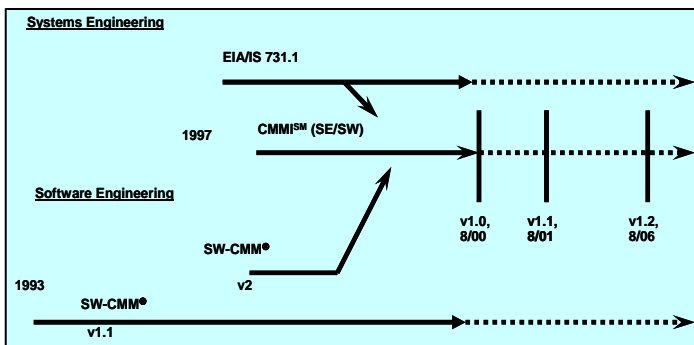

Figure 3: Evolution of the CMMI

By 2006 however most maturity model users had understood and gotten used to the two views. So when CMMI v1.2 was released there was just one document, with 22 Process Areas in alphabetical order, as well as some introductory material explaining the two structures. The appraisal method SCAMPI^{SSM} (Standard CMMI Appraisal Method for Process Improvement) was updated and now includes 3 classes of appraisals, A, B and C. Only a SCAMPI A can result in maturity or capability ratings.

Additionally, the concept of constellations was introduced. Some time next year, there will be three constellations:

- The CMMI that we all know (and love?) is called the CMMI for Development (CMMI-DEV)

- A CMMI for acquisition (CMMI-ACQ), which was released in Nov 2007
- A CMMI for services (CMMI-SVC), expected during 2009. A draft is available

Sixteen process areas are common to all three constellations.

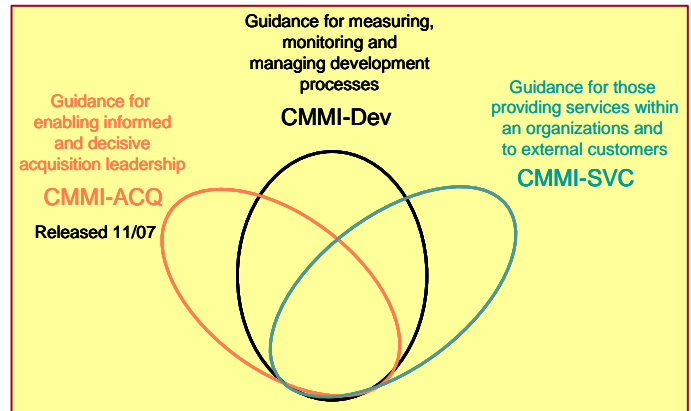

Figure 4: CMMI Constellations

Another change of importance that was introduced with v1.2, was an increased focus and much stricter controlling of High Maturity appraisals (maturity/capability levels 4 and 5). Lead appraisers must pass an exam in order to be authorized to lead high maturity/capability appraisals. All appraisals reporting level 4 or 5 are automatically sent to quality control.

The appraisal program is moving towards certification (instead of authorization) of lead appraisers, with an extra focus on ethics around process improvement consulting and leading appraisals.

There are several interesting technical reports that can be downloaded from the SEI website. A couple worth mentioning are a report on the ROI (Return On Investment) of CMMI based process improvement (CMU/SEI-2006-TR-004) and another on embracing both CMMI and Agile (in draft).

Team Software Process

Watts Humphrey and the SEI continue to spearhead PSP (Personal Software Process) and TSP (Team Software Process). PSP is a prerequisite for TSP. It was clear at the last SEPG conference that Microsoft was a big user of both these processes. In fact some conference participants tout TSP as the SEI’s agile team process.

Process Improvement in Small Settings

Small Settings is a completed initiative that the SEI ran together with a consortium of international researchers. The term Small Settings is defined as projects with 20 people or less and organizations with 50 people or less.

® SSMCMM Integration and SCAMPI are service marks of Carnegie Mellon University.
 ®® CMMI, Capability Maturity Model, Capability Maturity Modeling, and CMM are registered in the U.S. Patent and Trademark Office by Carnegie Mellon University.
 SSM CMM Integration and SCAMPI are service marks of Carnegie Mellon University.

CMMI and Six Sigma

A book on this topic has recently been released. The Six Sigma toolbox is one of the big enablers of High Maturity.

Process Improvement based on Multiple Models

A newly announced SEI project is PrIME (Process Improvement in Multimodel Environments). Many organizations attempt to use several reference models, standards, and improvement technologies. This often creates multiple improvement programs that could – in a worst case scenario – compete with each other for sponsorship, resources and – not least - the “mind space” of those who are the end users of all these

improvement programs. The approach to be taken by PrIME is to develop methods to harmonize various improvement models and standards.



The above should give you, dear reader, a taste of what is happening in the SEI world...and I am nearing the end of my allotted space.

Winifred Menezes

*Authorized SCAMPI A/B/C and High Maturity Lead Appraiser,
Introduction to CMMI Instructor*

News from SEI

We often get valuable information sent to us by Shane McGraw of SEI. Shane coordinates collaboration across all SPINs around the world. As we see information that would be valuable to our community, we will include it in this section.



SEPG North America 2009 Conference

The SEPG North America 2009 Conference will be held on March 23-26, 2009, in San Jose, California. We've made it easier than ever to suggest keynote speakers and program topics for the conference. Just go

to www.sei.cmu.edu/sepg/2008/news_2009.html on the the SEPG North America 2008 Post-Conference site, and click on the links to submit your ideas.

These two calls will be open through August 1, 2008, but get those ideas in early to have a better chance of influencing the program. Attached is a preliminary list of topics for the Call for Abstracts for SEPG North America 2009. This is of course subject to change.

And while you're on the SEPG North America 2008 Post-Conference site www.sei.cmu.edu/sepg/2008/index.html, enjoy the highlights, comments, reviews, our Top 10 Presenters, and more from the 2008 conference in Tampa, Florida.

Also, check back on July 1, 2008 when the SEPG North America 2009 web site opens with the Call for Abstracts and Call for Reviewers. This year, SPIN members who are selected to review abstracts will make up the Review Board for SPIN (formerly the Program Committee). They will receive a certificate of participation and be listed in the final program.

*From Shane McGraw
SEI SPIN Coordinator*



Call For Volunteers

We continue our journey of fast-paced growth – and need active volunteers to join the volunteer team. Our current volunteer team consists of people who live as far away as Waterloo. So it doesn't really matter where you live or work. The majority of our work is done remotely from our normal work locations via teleconference calls. Occasionally, we coordinate face-to-face meetings, but mostly we see each other in-person at the conference events.

If you are interested in volunteer opportunities with Toronto SPIN, please send an email to volunteers@torontospin.com. You will be invited to attend a one-hour volunteer orientation session that will give you a full overview of how Toronto SPIN is organized so you can determine if, and how, you want to participate.

Following are some specific roles for which we are actively recruiting.

Call for Web Developers

Do you have 4 to 6 hours spare time per week? Do you have skills in HTML, PHP, MySQL, CSS, JavaScript, AJAX, XML and knowledge of FTP?

Toronto SPIN continues to look for individuals in the Toronto software community that are interested in volunteering their time and skills to help with maintenance and the development of new functionality for the Toronto SPIN website. We're looking for web developers interested in helping us continue to improve our website.

If you have these skills and interested in this volunteer opportunity, please send an email to volunteers@torontospin.com.

Call for an Election Officer

In the past, we have never had a fully staffed Steering Committee, so running formal elections has not been a requirement. We now have almost 2 dozen current volunteer team members and an election is now necessary.

We plan to run a formal election for the August 2009 – July 2010 fiscal year. Our goal is to have the election take place by March 31st, 2009 to select the Steering Committee for the following fiscal year.

We are actively looking for a volunteer to lead the election process. If you are interested in this role, please send an email to volunteers@torontospin.com.

Call for Event Managers

As we continue to bring more events to the community, we need more people to lead the planning, coordination, reporting and general management of the conference events. We have been doing events for

many years and have developed reusable templates and guidance documentation.

If you have good project management and coordination skills, this is a great opportunity to come and help us organize an event. From start to finish, an event takes approximately 3 months. We recommend that Event Managers first volunteer for at least one event as an Event Management Team member, then play the role of Event Manager Backup for at least one event. After that, they are fully trained and experienced to be Event Managers for future events.

If you are interested in getting started on the path to becoming an Event Manager, please send an email to volunteers@torontospin.com.

Rekha Kulshreshtha

TSPIN Volunteer Sub-Committee Lead

Toronto SPIN Volunteer Team

Toronto SPIN would not be operational without the support of dedicated volunteers. Many thanks to all our volunteers.

Name	Company
TSPIN Steering Committee Members	
Doris Concepcion	IBM Canada Ltd.
Andrew Gurudata	Telus Mobility
Sanford Hersh	Computer Elations Inc.
Rekha Kulshreshtha	IBM Canada Ltd.
Susan Muckle	Ontario Energy Board
Vivienne Suen	IBM Canada Ltd.
Steven Turner	ESI Canada
Rodolfo Zuniga	IBM Canada Ltd.
Winifred Menezes	Freya Consulting Ltd.
Erika Vintan	Bank of Montreal
Kirk Zapa	KayCee Inc.
Volunteer Team Members	
Emmanuel Gonnet	Gem Up Consulting
Victoria Johnston	IBM Canada Ltd.
Orhan Kalayci	Smart Systems for Health Agency
Renay Langdon	Smart Systems for Health Agency
Joyce MacDonald	Gregory Consulting Ltd.
Ruben Montero	IBM Canada Ltd.
Jenna Munro	IBM Canada Ltd.
Sachin Quadros	IBM Canada Ltd.
Hamid Yazdapanah	IBM Canada Ltd.
Nancy Xiau	IBM Canada Ltd.
Juana Zegarra	CGI Inc.
Jian Zhang	Large Canadian Bank